



OptoTech

# Product Catalogue

Consumables

Precision Optics





## Content

---

Introduction: OptoTech Consumables & Tooling .....	3
Coolants.....	4
Centering Oil .....	8
PU Foil .....	9
Novotext & Synthetic Resin.....	10
Polishing Pitch & Polishing Wax.....	11
Polishing Powder .....	12
Contact Glue .....	15
Precision Runners.....	16
Measuring Equipment .....	17
Cleaning Equipment.....	21
Lens Protection Tape .....	23
Tooling: Diamond Pellets.....	24
Tooling: Diamond Cup Wheels .....	25
Tooling: Diamond Wheels & Straightening Stones .....	28
Tooling: Diamond Cup Wheels Electroplated .....	29
Tooling: KombiTools .....	31
Tooling: Centering Wheels .....	32
Tooling: Centering Bells .....	33
Tooling: Rubber Membranes .....	34
Tooling: Basic Chucks, Polishing Membranes & FEM Tool Kits .....	35
Tooling: A-FJP Tool Kits & Polishing Pins .....	36
Tooling: A-WPT Tool Kits & Wheel Polishing Tools .....	37
Tooling: Tool Kit Excenter Ball Pin & Pitch Polishing Tools .....	38
Tooling: Lens Specific Tools .....	39



## Introduction: OptoTech Consumables & Tooling

The best machines and systems can only provide top performance if the tools and consumables are ideally matched to the process. OptoTech's range of consumables provides you with a comprehensive solution for all of your applications. All of our products have been extensively tested and specially matched to our machines and systems. Some of our tool concepts are unique, thus underscoring the cutting-edge technology of our processes. Optimised production is only made possible by combining our machines with high-quality tools and consumables. Our range of offerings includes all types of grinding and polishing tools, cooling lubricants and polishing fluids, as well as special tools, special adhesives, protective lacquers and films, polishing foils and polishing pads.

Every lens has its own character, and thus we make it possible to adjust standard tools to customer-specific applications at any time. Upon request, we can even supply you with the entire manufacturing process for an optical component. As a company with more than 30 years of experience in the field of optics machine manufacturing, OptoTech always provides you with a complete solution from a single source.

## Coolant KE 500

---



KE 500 is a mineral oil free water soluble coolant for processing optical glass with diamond tools.

### Technical Data

Colour:	yellow
Viscosity (20°C):	12 mm <sup>2</sup> /s
pH-Value:	9.3
Refractometer factor:	1.8
Concentration:	2% to 4%

### Comment

KE 500 is free from phenols, nitrite, silicone and PCB/PCT, PTBB as well as other dangerous and/or raw materials with labelling obligation. Further advantages of KE 500 are:

- high corrosion protection
- low foaming
- good machine care
- very environmentally-friendly
- good skin tolerance

Packing units on request

**Art. No.: KM-28-0002**

Also available: Compatible **de-foamer**

**Art. No.: KM-28-0001**

## Coolant Fluid G44

Fluid G 44 is a full synthetic, mineral oil free water soluble coolant for processing ceramics, flat-, optical- and crystal glass. It can also be used for processing steel and non iron metals like copper.

### Technical Data

Colour:	light yellow
Viscosity (20°C):	8mm <sup>2</sup> /s
pH-Value:	9.4
Refractometer factor:	2.0
Concentration:	3% to 4%

### Comment

Fluid G 44 is free from chlorine, phenols, nitrite, silicone, PCB/ PCT and PTBB as well as other dangerous and/or raw materials with labelling obligation.

Further advantages of Fluid G 44 are:

- high economic
- low foaming
- good rust protection and cooling impact
- good rinsing
- good skin tolerance

Packing units on request

**Art. No.: KM-29-0004**





## Coolant Fluid G 46

---

Fluid G 46 is a full synthetic, mineral oil free water soluble coolant for processing ceramics, flat-, optical- and crystal glass. It can also be used for processing steel and non iron metals like copper.

### Technical Data

Colour:	light yellow
Viscosity (20°C):	8 mm <sup>2</sup> /s
pH-Value:	9.4
Refractometer factor:	2.0
Concentration:	3% to 4%

### Comment

Fluid G 46 is free from chlorine, phenols, nitrite, silicone, PCB/PCT and PTBB as well as other dangerous and/or raw materials with labelling obligation.

Further advantages of Fluid G 46 are:

- high economic
- low foaming
- good rust protection and cooling impact
- good rinsing
- good skin tolerance

Packing units on request

**Art. No.: KM-29-0003**

## Coolant Leko-Fluid 16 DL

Leko-Fluid 16 DL is a full synthetic, mineral oil free water soluble coolant for processing ceramics, flat-, optical- and crystal glass. It can also be used for processing steel and non iron metals like copper. Developed to improve the processing of quartz glass at lowest possible concentrations (3 %).

### Technical Data

Colour:	light yellow
Viscosity (20°C):	8 mm <sup>2</sup> /s
pH-Value:	9.4
Refractometer factor:	1.4
Concentration:	3% to 5%



### Comment

Leko-Fluid 16 DL is free from chlorine, phenols, nitrite, silicone, PCB/PCT and PTBB as well as other dangerous and/or raw materials with labelling obligation.

Further advantages of Leko-Fluid 16 DL are:

- high economic due to low concentration
- low foaming
- good rust protection and cooling impact
- good rinsing
- good skin tolerance

Packing units on request

**Art. No.: KM-29-0005**

Also available: Compatible **de-foamer**

**Art. No.: KM-29-0007**

## Centering Oil ZO 100 / ZO 500 S

---



**ZO 100** is a high performance coolant oil for generating and centering precision optics with diamond tools.

### Technical Data

Colour: neutral  
Viscosity (40°C): 7.2 mm<sup>2</sup>/s  
Flashpoint: 155°C

**Art. No.: KM-22-0002**

**ZO 500S** is a high performance coolant oil for generating and centering precision optics with diamond tools.

### Technical Data

Colour: neutral  
Viscosity (40°C): 4.3 mm<sup>2</sup>/s  
Flashpoint: 128°C

### Comment

ZO 500S is free from phenols, PCB/PCT, PTBB, chlorine zinc and barium. Further advantages of ZO 500S are:

- good skin tolerance
- low foaming
- little mist formation
- high efficient
- good sedimentation

Packing units on request

**Art. No.: KM-29-1201**



## PU-Foil

Our polyurethane foil perfectly suits for polishing precision lenses, ophthalmic lenses, flat optics or ceramic surfaces. The Polyurethane, which is made up of millions of porosities, is also available as drenched material. The drenching enhances the action and increases stock removal, while minimizing free particles that can contribute to scratching. Even with the drenched material it requires the usage of polishing slurries like cerium- or zirconium oxide.

Dimensions:

Standard Sheet: 1400 mm x 580 mm

Standard Thickness:

0.51mm; 0.81mm

On request:

1.02 mm; 1.27mm

2.03 mm; 3.18 mm; 6.35 mm; 12.7 mm



### Sample applications PU Foil

Type	Colour/Filled	Shore „D“	Applications
LP 26	pink / Zirconium Oxide	33-43	camera lenses, flat glass, mirrors
GR 35	gray / Zirconium Oxide	33-43	plano optics, micro optics, round optics
LP 46	dark green / Zirconium Oxide	20-30	sapphire, TV screens

*Others on request*

## Pencil

STAEDTLER Lumcolor refillable pen. Especially suited for use on PU-Foil.

Colour: red

**Art. No.: GE-15-0008**

**Pencil**

**Art. No.: GE-15-0009**

**Refill Leads**



## Novotext

---



Novotext is a high performance polishing ground based on textile fibre strengthened duroplast which is very suitable for polishing micro optics (Radius 1 mm to 7 mm).

This easy to handle rod shaped material is available in different diameters:

Individual sizes and dimensions on request.

Novotext is useable with all kind of polishing slurry types.

<i>Art. No.:</i> 01013300000635	Ø 8 mm
<i>Art. No.:</i> 01013300001000	Ø 10 mm
<i>Art. No.:</i> 01013300001200	Ø 12 mm
<i>Art. No.:</i> 01013300001300	Ø 13 mm
<i>Art. No.:</i> 01013300001500	Ø 15 mm
<i>Art. No.:</i> 01013300001600	Ø 16 mm
<i>Art. No.:</i> 01013300002000	Ø 20 mm
<i>Art. No.:</i> 01013300002500	Ø 25 mm
<i>Art. No.:</i> 01013300003000	Ø 30 mm
<i>Art. No.:</i> 01013300003180	Ø 32 mm
<i>Art. No.:</i> 01013300003500	Ø 35 mm
<i>Art. No.:</i> 01013300003810	Ø 38 mm
<i>Art. No.:</i> 01013300004000	Ø 40 mm
<i>Art. No.:</i> 01013300004500	Ø 45 mm
<i>Art. No.:</i> 01013300005000	Ø 50 mm
<i>Art. No.:</i> 01013300005500	Ø 55 mm
<i>Art. No.:</i> 01013300006000	Ø 60 mm
<i>Art. No.:</i> 01013300007000	Ø 70 mm
<i>Art. No.:</i> 01013300008000	Ø 80 mm
<i>Art. No.:</i> 01013300010000	Ø 100 mm

## Synthetic Resin

---



For stress-free cementing of lenses and prisms onto blocks. Also available as a cementing foil on a cotton backing. Melting point approx. 60°C. Oil proof.

Soluble in Parts-Ready and Acetone

***Art. No.:* KK-17-3201**

## Polishing Pitch

Polishing material based on natural resin for polishing precision optics. Our Polishing pitch is available in three degrees of hardness: soft, medium hard and hard.

**Art. No.: 910-60-0023**    *soft - 23*  
**Art. No.: 910-60-0028**    *medium - 27*  
**Art. No.: 910-60-0037**    *hard - 37*  
**Art. No.: 910-60-0043**    *hard - 43*



## Polishing Wax

*Polishing wax made of natural materials such as beeswax, colophonium and paraffin. This polishing wax can be used for many optical applications, e.g. for polishing plano-surfaces and for cementing lenses and prisms. Ideal for stress-free cementing of complex lenses and prisms.*

*Melting point: approx. 60 to 70°C*

**Art. No.: KK-17-3202**    *medium*  
**Art. No.: KK-36-0001**    *hard*



## Cerox / Opaline

---



**Cerox 1663** is a rare earth oxide based powder particularly suited for polishing ophthalmic lenses (mass production and prescription) and optical glass. This product provides excellent suspension characteristics, a high polishing efficiency and high cleanliness.

Technical Data:

pH-value:	6.0 to 7.0
Colour:	white
Particle size:	0.9 to 1.3 $\mu\text{m}$

**Art. No.: PM-19-2201 Cerrox 1663**

**Opaline** is an extremely pure (white) cerium oxide compound. Strict control over the entire critical parameters (hardness, shape, size, and allocation) make Opaline the perfect choice for high precision polishing of all types of glass materials that require a critical surface .

Technical Data:

pH-value:	7.0
Particle size:	0.4 to 1.0 $\mu\text{m}$
Colour:	white
Delivery units:	20 kg Containers

**Art. No.: PM-17-2203 Opaline**

## FERRO

### CERI 5005 Cerium Oxide

Colour: white powder  
 pH-value: 5.8 to 7.5  
 Particle size: D50... 1.1 to 1.8  $\mu\text{m}$   
 Concentration: 5 to 10% solid  
 Delivery units: 20 kg Containers

**Art. No.: PM-14-2202 CERI 5005**



### SRS 848 Cerium Oxide powder

pH-value: 3.75 to 4.75  
 Particle size: 0.4 to 1.0  $\mu\text{m}$   
 Concentration: 5 to 10%  
 Suspensions treated  
 Delivery units: 20 kg Containers

**Art. No.: PM-14-2305 SRS 848 Cerium Oxid**

### ZOX N Zirconium Oxide

ZOX N is an aqueous zirconium oxide slurry used in precision polishing of soft crystals, IR filters, camera lenses and final polishing on BK-7 products.

pH-value: 5.5 to 6.5  
 Particle size: 1.0 to 1.35  $\mu\text{m}$   
 Delivery units: 20 kg Containers  
 Used for soft glass, IR-Filters, BK7  
 Final Polishing and Pitch Polishing

**Art. No.: PM-14-2306 Zox N**

## Ultra Sol



**Ultra-Sol 200A** is an acidic colloidal alumina dispersion, with advanced chemical-mechanical action, that provides superior surface finishes. Ultra-Sol 200A is for use with: germanium, silicon, gallium arsenide, zinc sulfide, zinc selenide, fluorides, ferrites and silicon carbide.

Technical Data:  
 pH: 3.5 to 4.0  
 % Solids: 20%  
 Particle size: 1.0  $\mu\text{m}$   
 Viscosity: Thixotropic

**Art. No.: PM-14-2302**

**Ultra Sol 500S** is a non-drying form of colloidal silica especially designed to provide a final step polishing for most optical crystals.

**Art. No.: PM-14-2303**

## Compol-80



Ingredients: 40% Silicone dioxide; 60% Water

Technical Data:  
 Colour: milky white  
 pH: 9.5 to 11  
 % Solids: 20%  
 Particle size: 75nm  
 Viscosity: 3.0mPa x s

**Art. No.: PM-78-2301**

## Hastilite Cerium Oxide



**Hastilite Cerium Oxide Slurry:**  
 High quality polishing slurry. The base material is a rare earth oxide which has been precipitated out of a chemical solution and calcined at optimum temperature to yield a optimized particle morphology. The solution is further enhanced with other chemicals. Final processing and sizing procedures procure a narrow sub micron particle size distribution.

Hastilite PO produces sleek free surfaces with qualities of Angstrom levels.

Technical Data:  
 Colour: white  
 pH: 7-8 (5% Slurry)  
 % Solids: 30%

Distributed in 5 kg pots of concentrated slurry

**Art. No.: PM-14-2201**

## UV Glue

**Vitralit 6127** is a solvent-free, crystal clear single-component UV-cement based on Aethoxyaethylacrylat and B-Hydroxymethylmethacrylat for cementing precision optics on metal frames.

**Technical Data:**

Viscosity	20 to 100
Temperature Resistancy	-40 to 120°C
Refractivity	1.501
Shore D	70 to 80

**Art. No.: 10040400061040**

**Dura Hold** is a solvent-free, ultraviolet glue specifically for use in precision optics manufacturing. The product provides structural integrity during the generating, grinding and polishing operations, and can be removed easily after soaking in a heated, aqueous deblocking solution.

**Technical Data:**

Viscosity	40.000cP
Flash Point	max. 150°C
Shore	60
Brookfield	1.15

**Art. No.: KK-34-3301**



## Technicoll 8266/8267

Two component glue based on epoxy resin. Technicoll gives a very strong compound which is particularly suitable for gluing diamond pellets on curve tools. The glue hardens faster if heat is applied.

Packing: Tubes a 60g/70g

**Art. No.: KK-25-0001**



## Pattex

This special adhesive based on polychloropren is suitable to glue all kind of polishing foils like polyurethane, desmopan, desmoflex or polishing felt on tools in ophthalmic or precision optics.

Please follow the instructions for using Pattex which is supplied with each pack.

Delivery unit 125g tubes

**Art. No.: KK-43-0001**





## Precision Runners

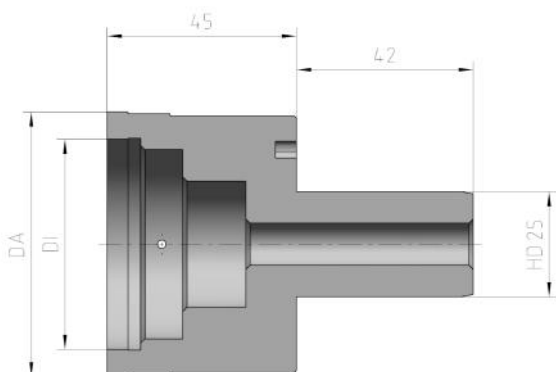

We offer several high-quality precision runners for aspheres in different inside and outside diameter configurations with HD25 connection.

<b>Article Number</b>	<b>Outside Diameter (DA)</b>	<b>Inside Diameter (DI)</b>	<b>Connection</b>
Art. No.: 790-35-002	Ø2mm	Ø1mm	HD25
Art. No.: 790-35-005	Ø5mm	Ø3mm	HD25
Art. No.: 790-35-008	Ø8mm	Ø5mm	HD25
Art. No.: 790-35-009	Ø9mm	Ø5.5mm	HD25
Art. No.: 790-35-010.1	Ø10mm	Ø6.3mm	HD25
Art. No.: 790-35-012	Ø12mm	Ø7.1mm	HD25
Art. No.: 790-35-014	Ø14mm	Ø8mm	HD25
Art. No.: 790-35-015	Ø15mm	Ø9mm	HD25
Art. No.: 790-35-016	Ø16mm	Ø10.5mm	HD25
Art. No.: 790-35-018	Ø18mm	Ø12.5mm	HD25
Art. No.: 790-35-020	Ø20mm	Ø13mm	HD25
Art. No.: 790-35-025	Ø25mm	Ø18mm	HD25
Art. No.: 790-35-028	Ø28mm	Ø20mm	HD25
Art. No.: 790-35-032	Ø32mm	Ø25mm	HD25
Art. No.: 790-35-036	Ø36mm	Ø28mm	HD25
Art. No.: 790-35-040	Ø40mm	Ø32mm	HD25
Art. No.: 790-35-045	Ø45mm	Ø36mm	HD25
Art. No.: 790-35-050	Ø50mm	Ø40mm	HD25
Art. No.: 790-35-051	Ø50mm	Ø43mm	HD25
Art. No.: 790-35-056	Ø56mm	Ø45mm	HD25
Art. No.: 790-35-063	Ø63mm	Ø50mm	HD25
Art. No.: 790-35-071	Ø71mm	Ø63mm	HD25
Art. No.: 790-35-080	Ø80mm	Ø71mm	HD25
Art. No.: 790-35-090	Ø90mm	Ø80mm	HD25
Art. No.: 790-35-100	Ø100mm	Ø90mm	HD25
Art. No.: 790-35-110	Ø110mm	Ø100mm	HD25
Art. No.: 790-35-125	Ø125mm	Ø110mm	HD25
Art. No.: 790-35-140	Ø140mm	Ø125mm	HD25



## Magnifier

A very solid magnifier with 6-, 8-, 12-, or 20-fold magnifying power.

<b>Art. No.: GE-15-0002</b>	<b>6x</b>
<b>Art. No.: GE-15-0003</b>	<b>8x</b>
<b>Art. No.: GE-15-0004</b>	<b>12x</b>
<b>Art. No.: GE-15-0005</b>	<b>20x</b>



## Measuring Magnifier

A very solid magnifier with 6, 8 or 10-fold magnification made of metal.

Metric comparison increments 0.1 mm, Linear scale 0 to 10 mm or 0 to 20 mm

<b>Art. No.: 910-40-0114</b>	<b>6x</b>
<b>Art. No.: 910-40-0113</b>	<b>8x</b>
<b>Art. No.: 910-40-0115</b>	<b>10x</b>



## Center Thickness Measuring Unit

Center Thickness Measuring Unit for lenses up to diameter 200 mm  
 Measuring gauge with 0.01mm scale  
 Max. measuring stroke 30mm  
 Measuring gauge height setting by a precision gear rack  
 Exchangeable lens holders

**Art. No.: 605-80-0002**



## Test- and Blocking Station LC



**Art.No.: 540-90-0050**

**Basic Unit**

Combination of a height measurement system and a blocking station. Various modules available on option, so the station can be used for measuring the thickness (e.g. lenses or tools) or for blocking of lenses on precision runners.

The basic unit consists of:

1. Hard coated aluminium plate with transport handles
2. High precision, manual Z-drive with measuring arm for analogue gauge (included) for C/T measurement

max. travel Z-Axis:	220 mm
Travel measuring gauge:	100 mm
Scale resolution measuring gauge:	0.001 mm
Dimensions (WxDxH):	360 x 350 x 700 mm

Modules available on option:

**Art.No.: 540-90-0053**

**Module for thickness measurement HD 40**

**Art.No.: 540-90-0056**

**Module for measuring KombiTools HD 25**

**Art.No.: 540-90-0057**

**Module for thickness measurement HD 25**

**Art.No.: 540-90-0054**

**Module for centering and cementing**

Different chucks available on option:

**Art.No.: 540-90-0051**

**HD 40 Chucks**

**Art.No.: 540-90-0052**

**HD 25 Chucks**

**Art.No.: 540-90-0055**

**HD 12 Chucks**

## Blocking Unit LC

**Art.No.: 540-90-0016 Basic Unit**

For high precision blocking of lenses in asphere production and lens production with integrated edging.

Including stand and Millimess measuring gauge.

Range of application:

- Serial cementing (with V-edge) up to  $\varnothing$  200 mm
- Single cementing up to  $\varnothing$  250 mm

Working principle: The lens will be layed down on the holder, adjusted according to the measuring gauge. In the next step the lens holder will be heated and blocked by a seperate heating source.

V-Edges on option:

<b>Art.No.: 540-12-044</b>	<b>10 mm &lt; <math>\varnothing</math> &lt; 60 mm</b>
<b>Art.No.: 540-12-045</b>	<b>60 mm &lt; <math>\varnothing</math> &lt; 130 mm</b>
<b>Art.No.: 540-12-046</b>	<b>130 mm &lt; <math>\varnothing</math> &lt; 200 mm</b>

Centering spindles on option:

<b>Art.No.: 540-45-0007</b>	<b>Centering Spindle with HD 40</b>
<b>Art.No.: 540-45-0009</b>	<b>Centering Spindle with HD 25</b>
<b>Art.No.: 540-45-0011</b>	<b>Centering Spindle with HD 12</b>

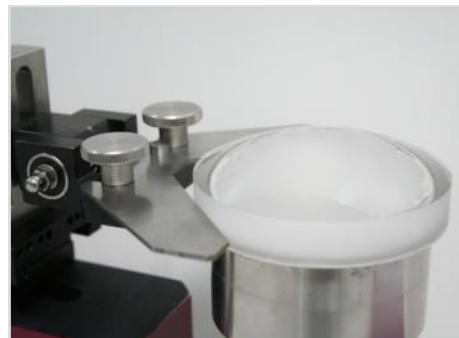
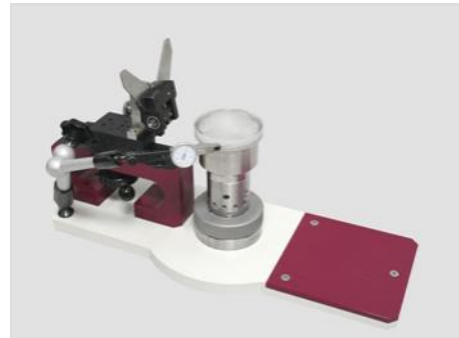

## Spherometer Rings

---



Measuring instrument for precision optics operation as well as the operation scheduling.  
The spherometer rings are available in diameters 1 to 100 mm.

Other diameters on request.

Measuring gauge and measuring pins separately available.

## Vacuum Pencil

---

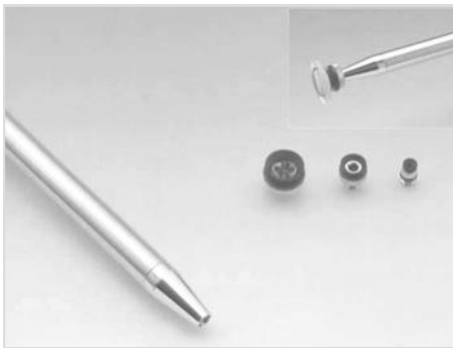

Vacuum pencil for easy handling of small lenses (micro optics)

Includes 3 different vacuum cup sizes:  
Vacuum cup Ø 6 mm for lenses Ø 5-10 mm  
Vacuum cup Ø 10 mm for lenses Ø 10-20 mm  
Vacuum cup Ø 14 mm for lenses Ø 20-45 mm

**Art. Nr.: GE-15-0017**

## Cleaning Cloth

Soft and lint-free cotton clothes for cleaning very sensitive surfaces. The clothes are free from silicone and washable by 90 °C in usual washing machines.

**Art. No.: RM-21-3301**    *lemon*  
 100% Cotton, low silicone  
 Size: 50 cm x 50 cm

**Art. No.: RM-83-3301**    *white*  
 TX 609  
 Size: 23 cm x 23 cm

**Art. No.: RM-83-3302**    *white*  
 TX 409  
 Size: 23 cm x 23 cm



## Sponges

Highly absorbent and durable viscose sponge

Free from silicone

**Art. No.: RM-35-0001**



## Hand Cleaner RM OI

---



OptoTech Cleaner and Preservative for final cleaning of coated lenses and prisms. Immediate end assembly is possible. The optical surfaces acquire an absolutely smooth and preserved surface.

**Art. No.: RM-17-0201**

## Protective Paint

---



Protective Paint using ethyl alcohol as solvent

Application: To protect polished surfaces against mechanical attacks

Colour: Black

Delivery Units: 1 kg or 5 kg

**Art. No.: SC-36-0001**

## Lens Protection Tape

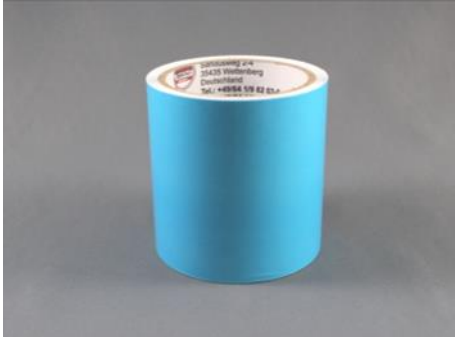

Tape for protecting lenses during the processing cycle. Excellent cohesion and easy removal.

Colour: Blue

Saver tape	Work piece	Dimensions (L x H)	Art.No.:
Optosave blue PLUS 35	Mineral+ Plastic	35 m x 0.1 m	SC-82-3301
Optosave blue PLUS 70	Mineral+ Plastic	70 m x 0.1 m	SC-82-3302
Optosave blue PLUS 105	Mineral+ Plastic	105 m x 0.1 m	SC-82-3304
Optosave blue PLUS 210	Mineral+ Plastic	210 m x 0.1 m	SC-82-3303

## Diamond Pellets



Sintered diamond pellets for lapping and fine-grinding of optical lenses in precision optics and ophthalmics.

Diameter 4 mm to 16 mm  
Thickness 2 mm to 5 mm

Other dimensions available on request.

All diamond pellets are also available in different bond and grit sizes. We supply C 23 as standard concentration. Other concentrations available on request.

### Comment

All required pellets for precision optics as well as ophthalmic optics are usually available ex stock. Furthermore we stock the appropriate adhesives and compound glues for the pellets.

*Diamond pellets*

<i>Diameter in mm</i>	<i>Thickness in mm</i>	<i>Concentration</i>	<i>Grit Size</i>	<i>Bond</i>
4	2/3	C23 / C35	D7 - D20 (others on request)	metal / resin
6	2/3			
8	2/3			
10	2/5			
12	5			
16	5			



## Diamond Cup Wheels HD6 & HD12

Sintered diamond cup wheels DIN 58741 for fine-grinding optical surfaces in precision optics.

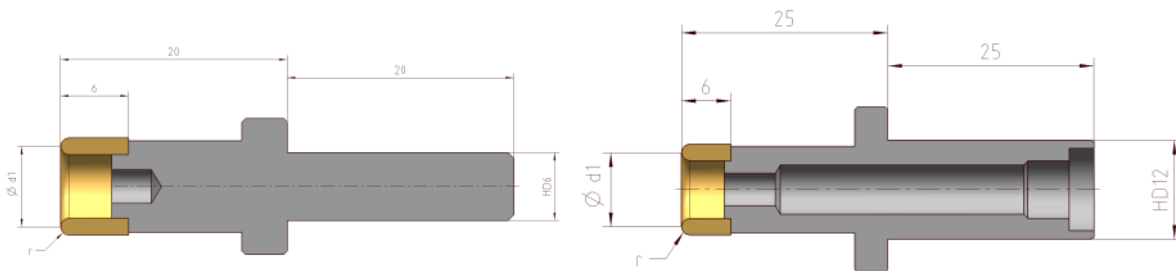

HD 6		HD 12	
d1	r	d1	r
Ø 3,0	0,5	Ø 3,0	0,5
Ø 4,0		Ø 4,0	
Ø 5,0		Ø 5,0	
Ø 5,6	0,75	Ø 5,6	0,75
Ø 6,3		Ø 6,3	
Ø 7,1		Ø 7,1	
Ø 8,0		Ø 8,0	
Ø 9,0	1	Ø 9,0	1
Ø 10,0		Ø 10,0	
Ø 11,0		Ø 11,0	
Ø 12,5	1,25	Ø 12,5	1,25
Ø 14,0		Ø 14,0	
Ø 16,0		Ø 16,0	
Ø 18,0		Ø 18,0	
Ø 20,0	1,5	Ø 20,0	1,5
Ø 22,0		Ø 22,0	
Ø 25,0		Ø 25,0	
Ø 28,0		Ø 28,0	
		Ø 32,0	

Grit size and concentration on request.

## Diamond Cup Wheels HD25



Sintered diamond cup wheels DIN 58741 for fine-grinding optical surfaces in precision optics.

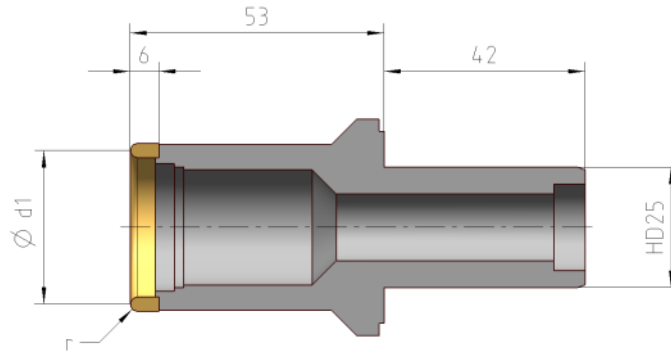

HD 25			
d1	r	d1	r
Ø 6.3	0.75	Ø 45.0	1.50
Ø 8.0	0.75	Ø 50.0	2.00
Ø 10.0	1.00	Ø 56.0	2.00
Ø 12.5	1.00	Ø 63.0	2.00
Ø 16.0	1.25	Ø 71.0	2.00
Ø 20.0	1.25	Ø 80.0	2.00
Ø 22.0	1.50	Ø 90.0	2.00
Ø 25.0	1.50	Ø 100.0	2.50
Ø 28.0	1.50	Ø 110.0	2.50
Ø 32.0	1.50	Ø 125.0	2.50
Ø 36.0	1.50	Ø 140.0	2.50
Ø 40.0	1.50	Ø 150.0	2.50

*Grit size and concentration on request.*

## Diamond Cup Wheels HD40

Sintered diamond cup wheels DIN 58741 for fine-grinding optical surfaces in precision optics.

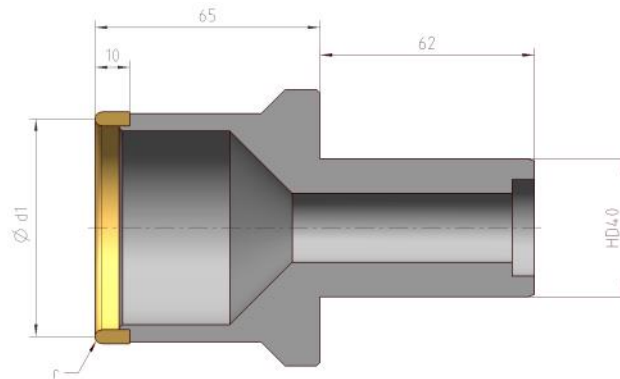

HD 40			
d1	r	d1	r
Ø 56,0	1,0	Ø 140,0	2,0
Ø 63,0	1,0	Ø 150,0	2,0
Ø 71,0	1,0	Ø 160,0	2,0
Ø 80,0	1,25	Ø 180,0	2,0
Ø 90,0	1,25	Ø 200,0	2,0
Ø 100,0	1,25	Ø 225,0	2,0
Ø 110,0	1,25	Ø 250,0	2,0
Ø 125,0	2,0		

*Grit size and concentration on request.*

## Diamond Wheels

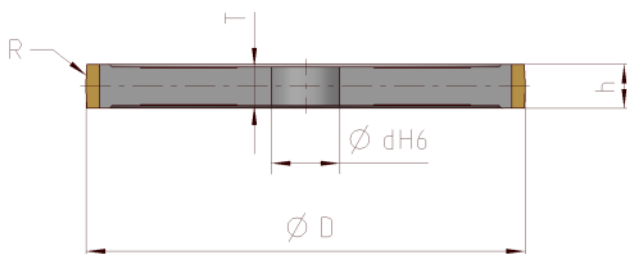
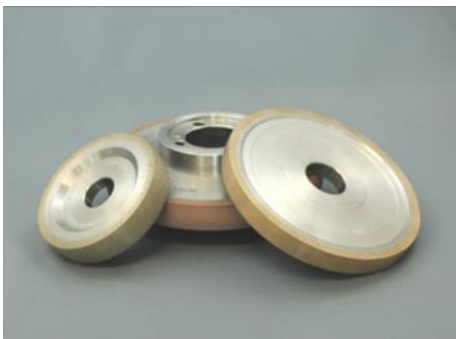

D	d	h	R	T
20	6	6	10	6
30	7	8	15	8
40	15	8	20	15
50	15	8	25	15
80	25	12	40	25
100	25	12	50	25
120	25	12	60	25

## Straightening Stones



Art. No.	Dimensions	Incl. HD Interface	Roughness
061-90-0079	$\varnothing 45 \times 50$	HD25	Fine
061-90-0080	$\varnothing 45 \times 50$	HD25	Rough
042-90-0007	$\varnothing 50 \times 50$ (tall version)	HD25	Rough
061-90-261	$\varnothing 45 \times 50 \times 10$ (with hole)	-	Fine
061-90-296	$\varnothing 52 \times 50$ (without hole)	-	Rough

## Diamond Cup Wheels HD12 Electroplated

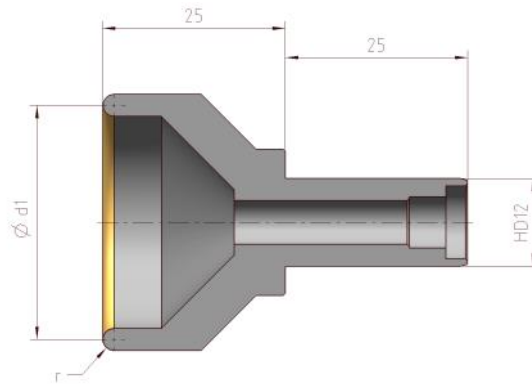

### HD12

d1	r	d1	r
Ø 5.0	1.00	Ø 14.0	1.25
Ø 5.6		Ø 16.0	
Ø 6.3		Ø 18.0	
Ø 7.1		Ø 20.0	1.50
Ø 8.0		Ø 22.0	
Ø 9.0		Ø 25.0	
Ø 10.0		Ø 28.0	
Ø 11.0		Ø 32.0	
Ø 12.5		Ø 36.0	
		Ø 40.0	

## Diamond Cup Wheels HD25 / HD40 Electroplated

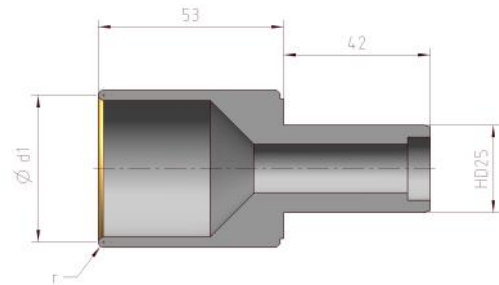

### HD25

d1	r	d1	r
Ø 8.0	1.00	Ø 36.0	1.50
Ø 9.0		Ø 40.0	
Ø 10.0		2.00	Ø 45.0
Ø 11.0			Ø 50.0
Ø 12.0			Ø 56.0
Ø 14.0	1.25	Ø 63.0	3.00
Ø 16.0		Ø 71.0	
Ø 18.0		Ø 80.0	
Ø 20.0	1.50	Ø 90.0	
Ø 22.0		Ø 100.0	
Ø 25.0		Ø 110.0	
Ø 28.0		Ø 125.0	
Ø 32.0			

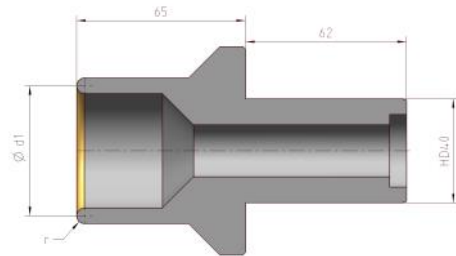

### HD40

d1	r	d1	r
Ø 80	3.0	Ø 160	5.0
Ø 90		Ø 180	
Ø 100		Ø 200	
Ø 110		Ø 225	
Ø 125		Ø 250	
Ø 140		Ø 280	
		Ø 300	

## KombiTools

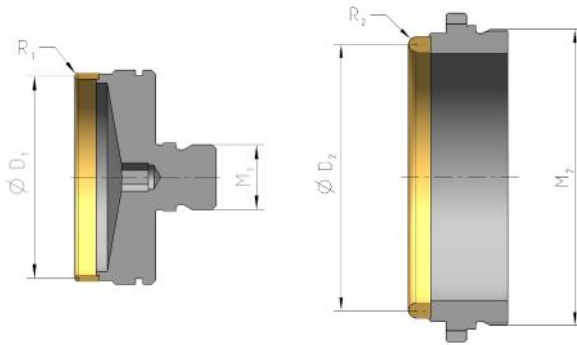

D1 mm	R1 mm	M1 mm	D2 mm	R2 mm	M2 mm
----------	----------	----------	----------	----------	----------

7.1	0.75	M5	11	0.75	M24x1
8			12.5		
9			14		
11			16		
12.5			18		
14			20		
16		M10	22		

D1 mm	R1 mm	M1 mm	D2 mm	R2 mm	M2 mm
----------	----------	----------	----------	----------	----------

18	0.75	M10	25	0.75	M38x1
20			25		
22			28		
25			32		
28			32		

D1 mm	R1 mm	M1 mm	D2 mm	R2 mm	M1 mm
----------	----------	----------	----------	----------	----------

32	0.75	M16	36	0.75	M60x1
36			40		
40			45		
45			50		
50			56		

## Centering Wheels

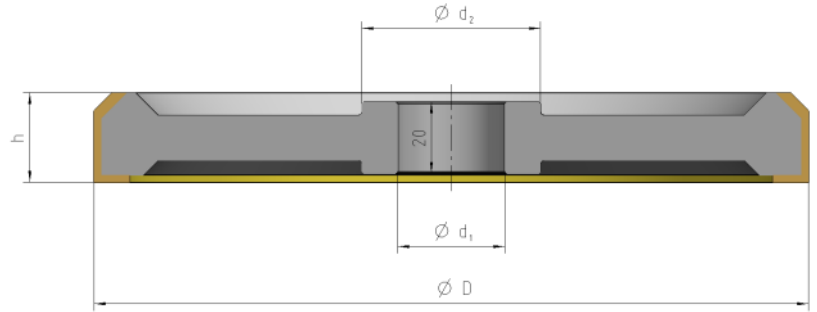

$d_1$	$d_2$	$d_3$	$h$	Machine Type
100	40	20	10	ZM 50 / ZM 25 WZM 20
120	40	20	10	
120	50	30	25	ZM 200 / WZM 150
160	50	30	25	
180	50	30	25	
200	50	30	25	

*Others diameters, grid sizes and concentrations on request*



## Centering Bells

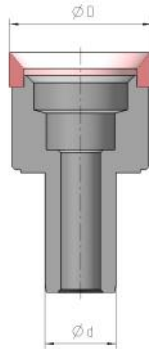

D	d	D	d	D	d
2.0	HD12	16.0	HD12 / HD25	65	HD12 / HD25
2.2	HD12	18.0	HD12 / HD25	67.5	HD25
2.4	HD12	20.0	HD12 / HD25	70	HD12 / HD25
2.6	HD12	22.5	HD12 / HD25	75	HD12 / HD25
2.8	HD12	25.0	HD12 / HD25	80	HD12 / HD25
3.0	HD12	26.5	HD12	85	HD25
3.2	HD12	27.5	HD25	90	HD25
3.4	HD12	28.0	HD12	95	HD25
3.6	HD12	30.0	HD12 / HD25	100	HD25
3.8	HD12	32.5	HD25	105	HD25
4.0	HD12	33.5	HD12	110	HD25
4.5	HD12	32.5	HD25	115	HD25
5.0	HD12	35.5	HD12	120	HD25
5.6	HD12	37.5	HD12 / HD25	125	HD25
6.3	HD12	40.0	HD12 / HD25	130	HD25
7.1	HD12	42.5	HD12 / HD25	140	HD25
8.0	HD12	45.0	HD12 / HD25	150	HD25
9.0	HD12 / HD25	47.5	HD12 / HD25	160	HD25
10.0	HD12 / HD25	50	HD12 / HD25	180	HD25
11.2	HD12 / HD25	52.5	HD12 / HD25	200	HD25
12.5	HD12 / HD25	55	HD12 / HD25	225	HD25
13.2	HD12	57.5	HD12 / HD25	250	HD25
14.0	HD12 / HD25	60	HD12 / HD25		
15.0	HD12	62.5	HD25		

## Rubber Membranes



Rubber membrane for holding optical lenses during the working process. All membranes are manufactured by OptoTech with a very high quality standard. Hereinafter you will see an overview of the available versions and dimensions. Furthermore you can also get customized membranes.

### Versions:

		Type No.	Ø DL	Area of Application
		<b>801</b>	10 mm – 340 mm	Flat bearing surfaces / Stable geometries
		804	12 mm – 120 mm	Concave surfaces / For small lenses
		808	17 mm – 110 mm	Concave surfaces / For small lenses
		810	17 mm – 55 mm	Concave surfaces / For small lenses
		<b>811</b>	12 mm – 110 mm	Universal / Radii fitting to lens radii / Edge pressure
		813	12 mm – 100 mm	For small lenses
		<b>814</b>	10 mm – 200 mm	For CX lenses
		<b>815</b>	14 mm – 160 mm	For CC lenses

*Others on request*

## Basic Chucks for Rubber Membranes

### Overview basic chuck

type	chuck connection	DIN
708-21-xxx	M10	58725
708-32-xxx	M16	58725
708-33-xxx	M27	58725
708-34-xxx	HD12	58725
708-35-xxx	HD25	58725
708-36-xxx	HD40	58725

xxx = Membrane diameter  
Adaptor M → HD available

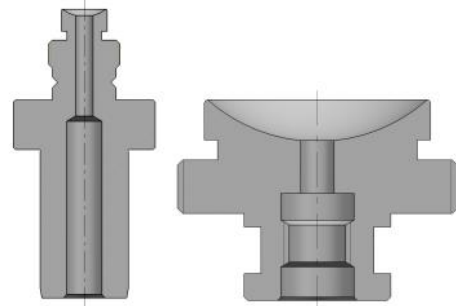

## Polishing Membranes

Art. No.	Diameter	Radius
12970161003500	Ø 16 mm	R10
12970342003500	Ø 34 mm	R20
12970524003500	Ø 52 mm	R40
12971008003500	Ø 100 mm	R80



## FEM Tool Kits

Art. No.	Tool Diameter	Connection
185-90-1000	Ø 16 mm	HD25
185-90-1001	Ø 34 mm	HD25
185-90-1002	Ø 52 mm	HD25
185-90-1003	Ø 100 mm	HD25

1 Tool kit contains: 1 FEM-Flex Tool incl. spare membranes, 1 Dressing Tool for FEM-Flex Tools

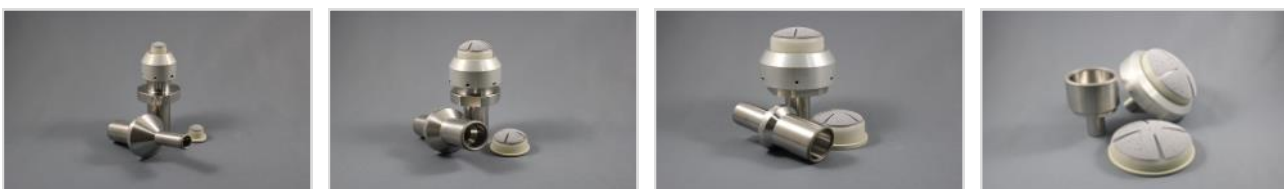

## A-FJP Tool Kits



<i>Art. No.</i>	<i>Tool Diameter</i>	<i>Connection</i>
185-90-1004	Ø 4 mm	HD25
185-90-1005	Ø 6 mm	HD25
185-90-1006	Ø 10 mm	HD25

1 Tool kit contains: 2 A-FJP nozzles, 1 base body, set of polishing pins

**NOTE:** To use these tools, the polishing machine has to be equipped with a C-axis

## A-FJP Polishing Pins



<i>Art. No.</i>	<i>Tool Diameter</i>
197-90-0032	Ø 4 mm
197-90-0026	Ø 6 mm
197-90-0027	Ø 10 mm

1 Tool kit contains: 20 polishing pins in storage box

## A-WPT Tool Kits

<i>Art. No.</i>	<i>Description</i>
198-90-0006	<i>Advanced wheel polishing tool version 2 Ø50 (A-WPT)</i>
198-90-0008	<i>Advanced wheel polishing tool version 2 Ø70 (A-WPT)</i>



**NOTE:** To use these tools, the polishing machine has to be equipped with a C-axis. Additionally, for each machine type, a special adapter kit is needed. Prices available on request.

## Wheel Polishing Tools



<i>Art. No.</i>	<i>Description</i>	<i>Technology</i>
195-90-0005	<i>Polishing Wheel Ø70x50</i>	Wheel Polishing Technology (WPT)
FZ-046-127-003	<i>Polishing Foil</i>	Wheel Polishing Technology (WPT)
198-90-040	<i>Polishing Wheel Ø50x15</i>	Advanced Wheel Polishing Technology (A-WPT)
FZ-046-127-004	<i>Polishing Foil</i>	Advanced Wheel Polishing Technology (A-WPT)
198-90-063	<i>Polishing Wheel Ø70x25</i>	Advanced Wheel Polishing Technology (A-WPT)
FZ-046-127-006	<i>Polishing Foil</i>	Advanced Wheel Polishing Technology (A-WPT)

## Tool Kit Excenter Ball Pin



<i>Art. No.</i>	<i>Description</i>
185-90-1011	Tool kit "excenter ball pin"

## Pitch Polishing Tools



<i>Art. No.</i>	<i>Description</i>
197-90-107	Pitch polishing tool Ø10mm R=plano for ball pin
197-90-104	Pitch polishing tool Ø20mm R=plano for ball pin
197-90-105	Pitch polishing tool Ø30mm R=plano for ball pin
197-90-106	Pitch polishing tool Ø40mm R=plano for ball pin

**NOTE:** Without lock plate and pitch

## Lens Specific Tools

Being a system supplier, OptoTech provides the opportunity to produce lens specific tools for your individual tasks. Just ask us. We would be very glad to send you a specific proposal for all necessary tools, based on your lens drawing. Whether polishing tools, collets, bodies or lens holders, OptoTech will deliver the ideal solution for your lenses.



*Bodies*



*Lens Holders*



*Polishing Tools*



*Collets*



# OptoTech

Contact

## Contact:



**OptoTech Optikmaschinen GmbH**  
Sandusweg 2 - 4  
35435 Wettenberg  
Germany  
T: +49 641 49939-0  
E: [info.de@optotech.net](mailto:info.de@optotech.net)  
W: [www.optotech.net](http://www.optotech.net)



**OptoTech S.r.l.**  
Via Romolo Murri 22/28  
20013 Magenta  
Italy  
T: +39 02 52804085  
E: [info.it@optotech.net](mailto:info.it@optotech.net)



**OptoTech AG**  
Luterbachstrasse 10  
4528 Zuchwil  
Switzerland  
T: +41 32 613 38 00  
E: [info.ch@optotech.net](mailto:info.ch@optotech.net)



**OptoTech Asia Ltd.**  
Room 22, 23/F, Metro Centre II  
21 Lam Hing Street, Kowloon Bay  
Hongkong  
T: +852 3568 3243  
E: [office@optotechhk.com](mailto:office@optotechhk.com)



**OptoTech Optical Machinery Inc.**  
PO Box 523  
Rockland, MA 02370  
USA  
T: +1 215 2670957  
E: [service.us-pa@optotech.net](mailto:service.us-pa@optotech.net)



**OptoTech Optikmaschinen GmbH**  
Damji Shamji Trade Centre 505  
5th Floor, Station Road  
Vidyavihar – W  
Mumbai – 400 086  
India  
T: +91 22 66 71 03 93  
E: [info.in@optotech.net](mailto:info.in@optotech.net)



# OptoTech

2024-10-16; Subject to change